

LEHNER **LIFTTECHNIK**

USER HANDBOOK



ALPHA
Stairlift
CE

Table of contents:

Introduction.....	3
Installation schematic	4
Technical parameters	5
Seat function overview	6
Controls	7
Starting up the chairlift	8
Sending and calling the chairlift from the hall calls	9
Seat rotation	10
Charging the battery.....	11
Fault detection and trouble shooting	11
Emergency drive wheel.....	12
Maintenance.....	12
Maintenance Record.....	14

Introduction

Congratulations for your curved stairlifts type Alpha. Before starting to use the stairlift, please read the operating instructions carefully in order to assure a safe and reliable operation of your stairlift.

Please observe the following guidelines:

Ensure that only qualified stairlift installers install and service the stairlift. Under no circumstances is anyone other than a qualified installer allowed to install, adjust, or service any mechanical or electrical device on this equipment. Failure to follow this warning can result in safety system compromises or defeat; this can result in serious injury or death. Lehner Lifttechnik GmbH accepts no liability for property damage, warranty claims or personal injury, in this circumstance.

Passenger safety is the result of countless details in the equipment's design, manufacture, and installation. After installation, reliable operation and continual safe operation requires regular service and inspection at least once per year, or more frequently where usage, environment, or local jurisdiction requires. As the owner, you are responsible for ensuring that regular service and inspections occur in a timely manner.

Refer to this manual for specifications, operating instructions and maintenance of your stairlift. Upon completion of installation, the dealer must provide you with the information below and ensure it is recorded in this manual. In addition, either the dealer or you must keep any service and/or maintenance records in the Maintenance Record section of this manual.

The chairlift may only be used by a person who is familiar with its use. People not meeting this requirement (for example children) may use the seat under the supervision of a competent person who takes the responsibility. Keep the keys for the seat in a secure place and do not leave the key in the switch on the armrest or on the hall calls when not in use.

Take the following precautions:

- The Alpha stairlift is intended solely for transporting one person sitting on the seat.
- Maximum loading capacity is 160kg
- Use the seatbelt while driving
- Before driving, make sure you sit safely on the chair and the swivel mechanism is securely engaged.
- Watch the driveway for obstacles while driving
- Do not drive standing on the seat
- Do not let children play on the seat or in the vicinity when using it.
- The seat is not designed to transport cargo.
- Protect the seat against misuse by unauthorized persons.
- To prevent accidents, adhere strictly to the instructions in this manual and keep clear of moving parts at all times.
- Ensure that only qualified personnel perform maintenance.
- Before calling or sending the lift make sure the driveway is clear and nobody is sitting on the chairlift.
- Do not use the lift in case of fire!

The lift is equipped with the following safety features:

- Drive with self-locking gearbox and motor brake
- Overspeed governor
- Safety contact edges on the sides of the drive unit and under the footrest
- Folding switch for armrest
- A two-position key switch located at the underside of the armrest.
- Overload current protection setting that corresponds to the load of approximately 160 kg
- Constant push controls - the lift always stops if the control joystick or the button on the hall call is released.

Installation schematic

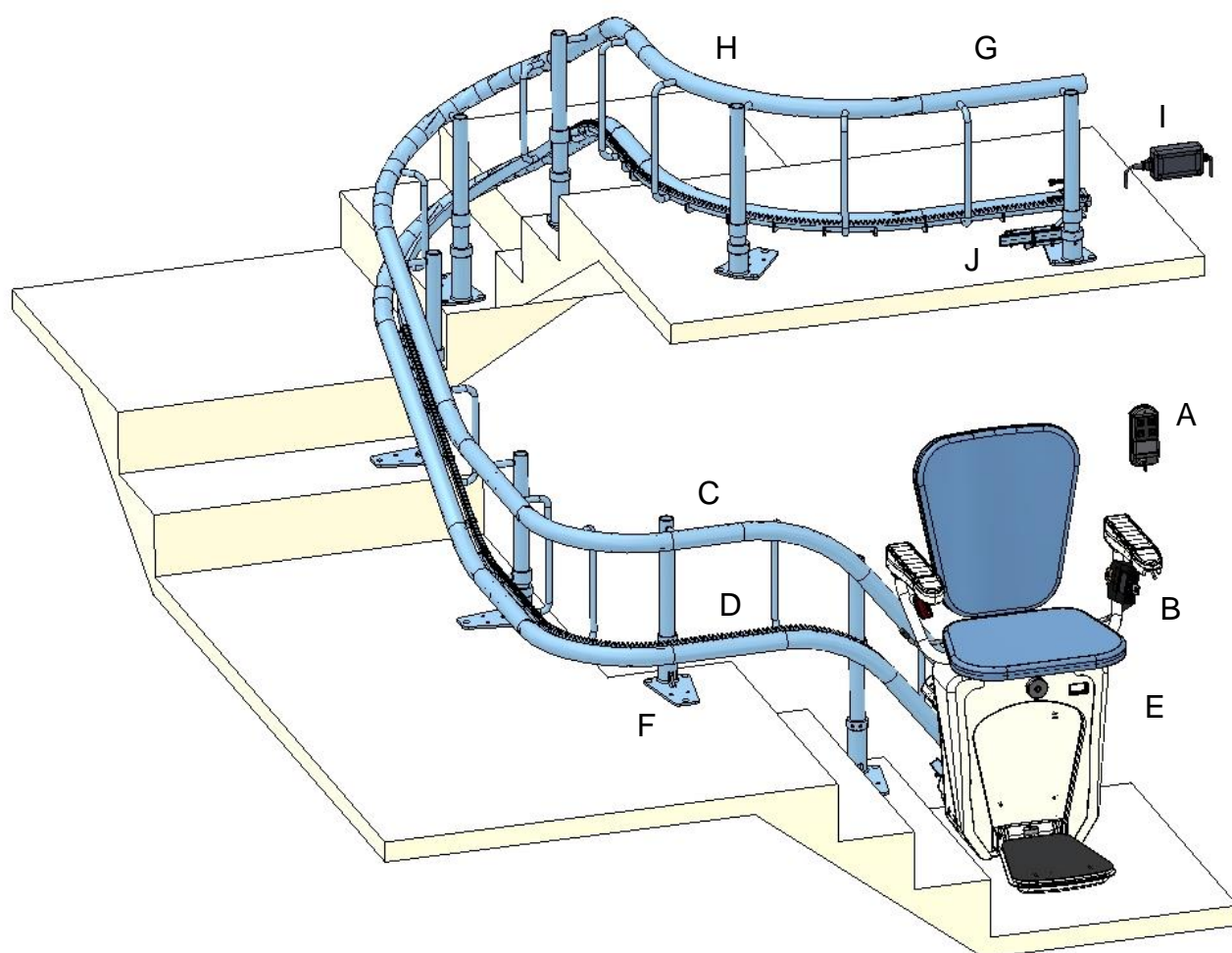

- | | | | |
|----|----------------------|----|--------------------------|
| A) | Hall call | F) | Pillar base plate |
| B) | Seat belt | G) | Upper stop |
| C) | Upper tube | H) | Horizontal parking curve |
| D) | Lower tube with rack | I) | Charger |
| E) | Lower stop | J) | Upper charging point |

Technical parameters

Applications	Residential or commercial indoor, curved stairs
Load capacity	160 kg
Seat size	460 x 326 mm
Travel speed	0.11 m/s on straight sections 0.06 m/s at bends
Range of incline	0° to 52°
Drive system	Rack and pinion
Operator controls	Constant-pressure type (joystick switch and remote control call/send units)
Seat belt	Retractable
Motor	0,37kW, 24 VDC
Charging	1x230V 50Hz AC or 1x110V 60Hz AC
Fold-up width	37 cm
Fold-out width	64.5 cm
Rail	Steel
Emergency operation	Full up and down travel on power interruption (full battery backup)
Warranty	24 months on parts, ask dealer for details
Noise	0° to 52°
Operation temperature	0°C to +40°C
Power	2 batteries 12V/9Ah, charging at landing stations
Seat height	496 mm from footrest

Seat function overview

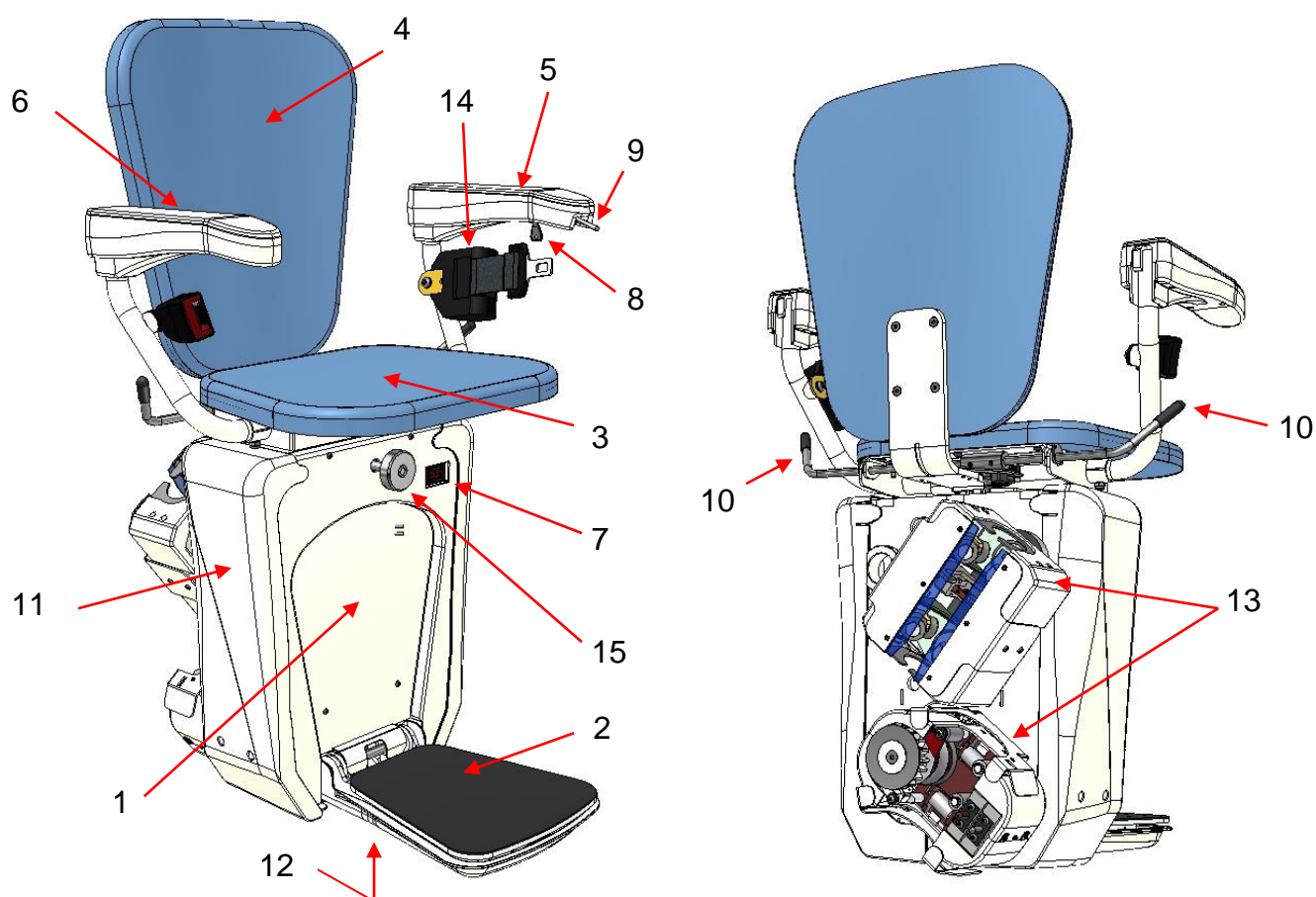

- | | |
|--------------------------|-------------------------|
| 1. Front cover | 9. Joystick in armrest |
| 2. Footrest | 10. Swivel lever |
| 3. Folding seat | 11. Side cover |
| 4. Backrest | 12. Footrest cover |
| 5. Left armrest | 13. Trolley covers |
| 6. Right armrest | 14. Seatbelt |
| 7. Main power switch | 15. Emergency handwheel |
| 8. Key switch in armrest | |

Controls

Control of the seat can be performed using the joystick direction located in the armrest or using one of the hall call remotes, located at each stop position.

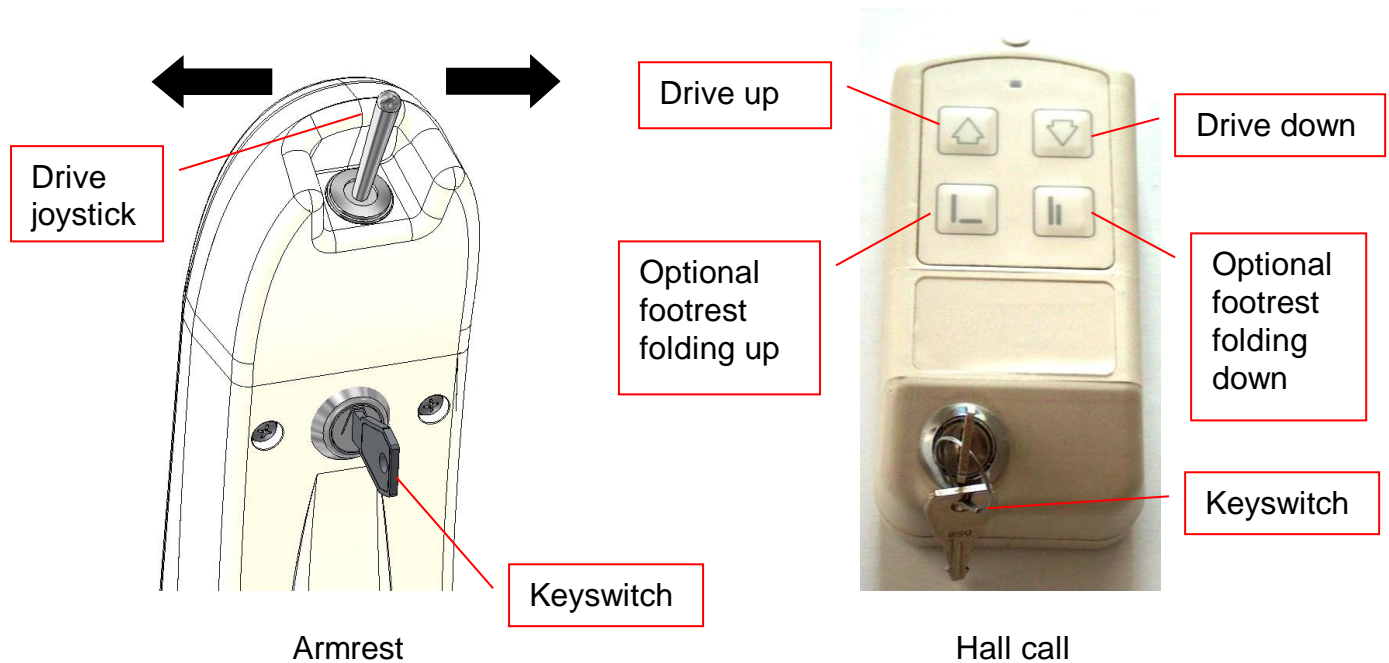

The keyswitch on the handset must be on in order to use the drive joystick. Also the keyswitch in the hall call must be on in order to call or send the chairlift.

Starting up the chairlift

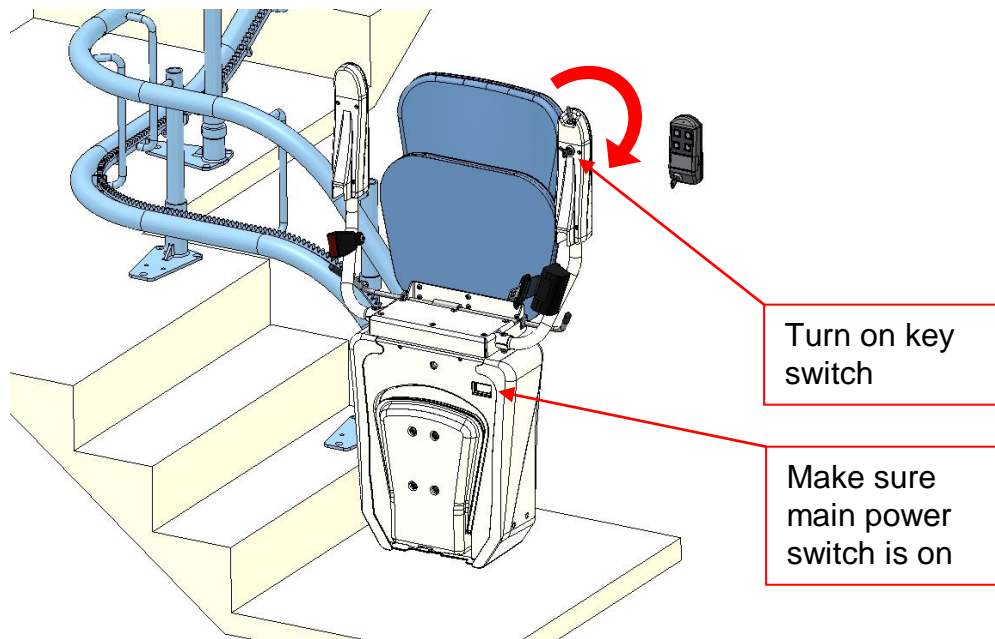

- 1) When unit is parked and folded up make sure the keyswitch and main power switch are on
- 2) Fold down the footrest, the folding seat and the armrest
- 3) Sit on the chairlift
- 4) Use the seatbelt
- 5) Use the joystick on the armrest by pushing it in the driving direction – there is a 3 second security time delay between the activation of the joystick and the start of the lift
- 6) The lift will drive as long as the joystick switch is being pressed and stops after releasing it or at the landing stop station.
- 7) Always watch in the driving direction for any obstacles while driving!

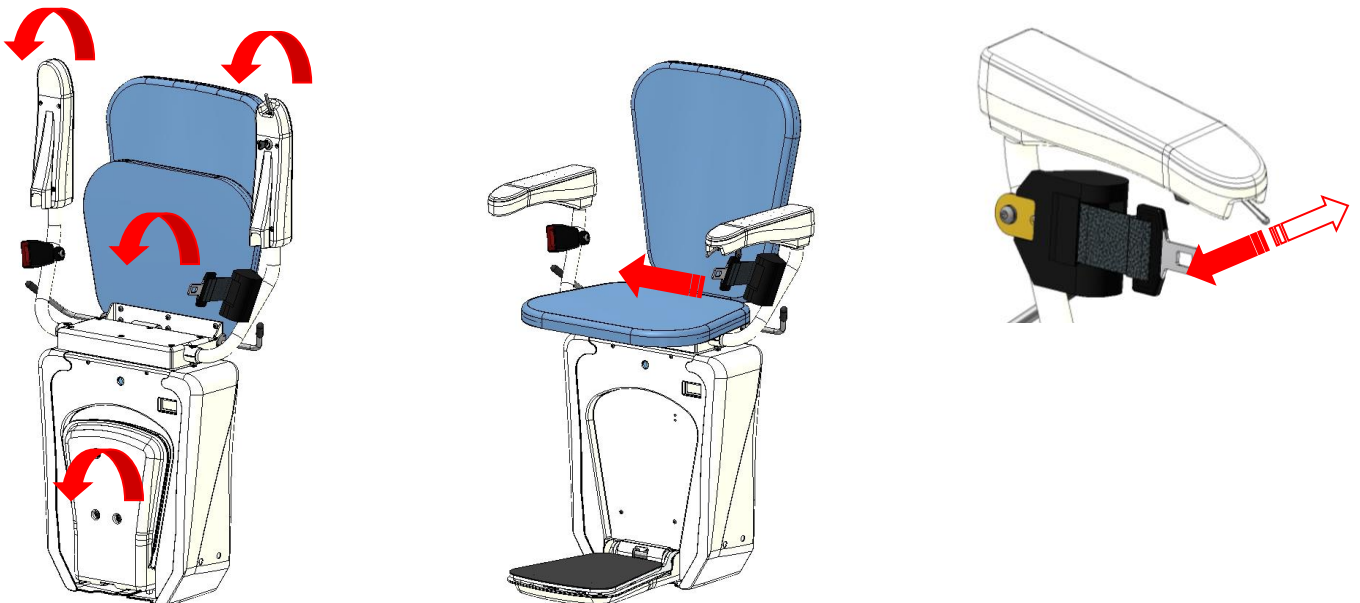

Sending and calling the chairlift from the hall calls

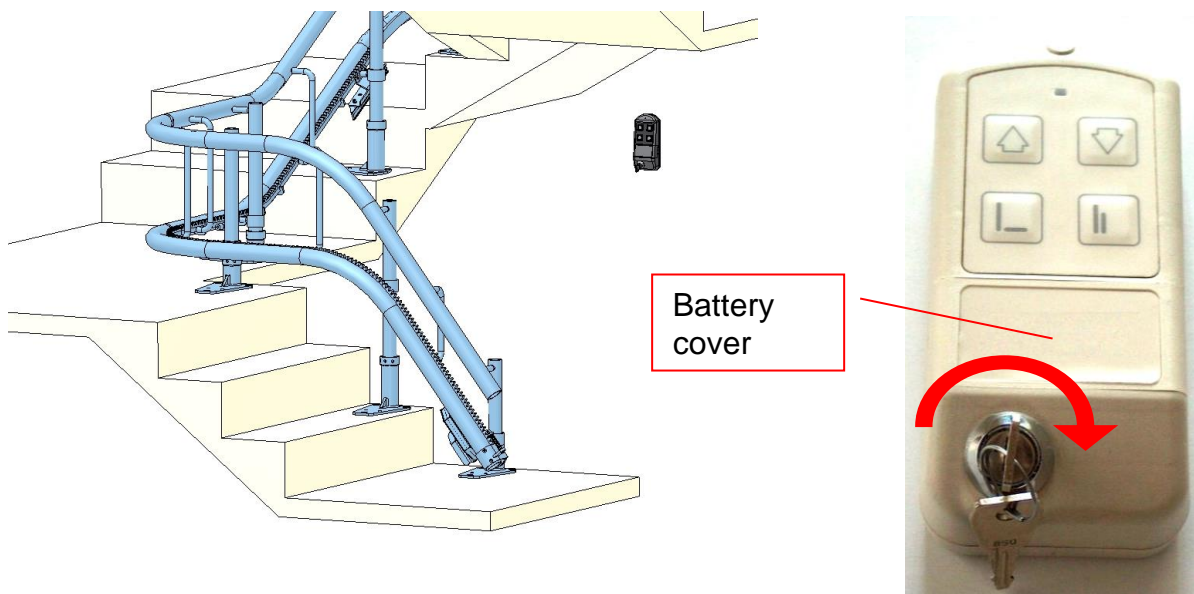

- 1) Make sure that the seat is not in use by someone else.
- 2) Turn on the hall call by inserting the key and turn it to the on position.
- 3) Call or send the seat by pressing the appropriate direction to the hall call.
- 4) The lift will drive as long as the directional button is being pressed and stops after releasing the button or when arriving in the landing station.
- 5) Press the directional button until the seat automatically stops at the landing stop.
- 6) Turn the key on the wall controller and take it with you.

Hall calls are usually supplied with two 1.5V AAA batteries. Battery life time is approximately one year, so the battery can be replaced during regular service visits (1 maintenance visit minimum every 12 months).

Battery function can be checked at any time. Each hall call has a green LED which flashes after being activated. If the LED indicator is off, the battery must be replaced.

Seat rotation

At the upper landing the seat can be rotated for easier entry and exit.

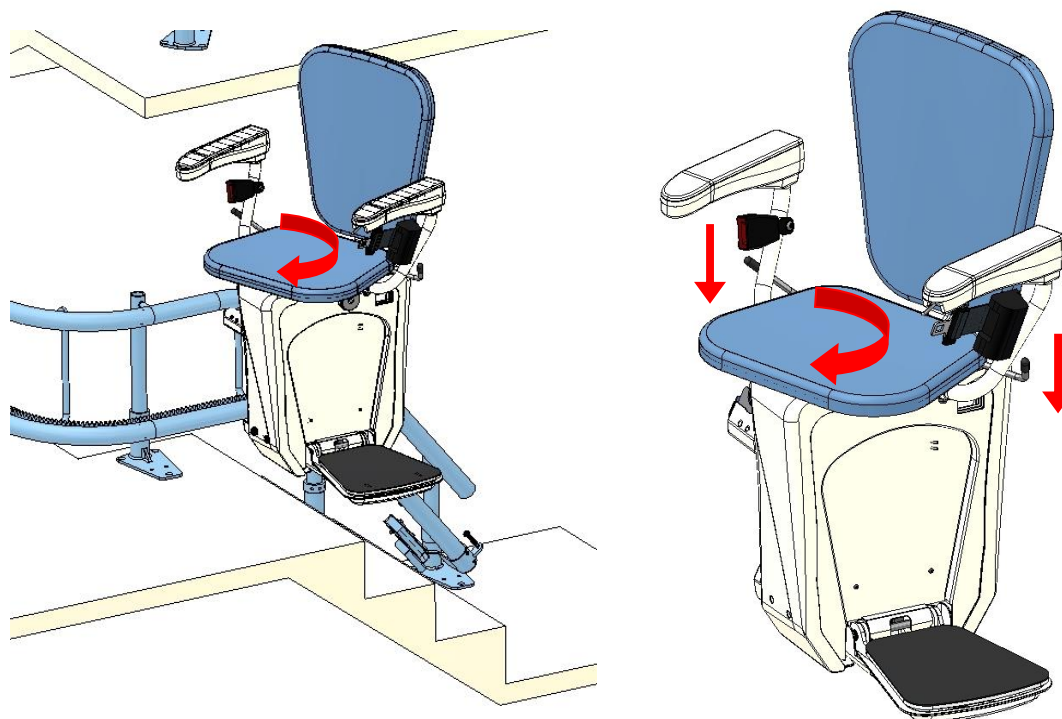

- 1) Push the lever to unlock the rotation (10) on the sides of the seat to its lowest possible position.
- 2) Turn the seat towards the upper side while still sitting on the seat.
- 3) There are 5 different swivel position at 0°, 20°, 45°, 70° and 90°. Release the swivel lever when the chair is in your desired position and make sure the swivel mechanism safely engages again at this position by pushing the lever back up into its original position. Then the seat should be locked at this position.
- 4) Carefully get out of the seat.
- 5) Turn the seat back to the drive position
- 6) If required you now can raise up again the footrest, folding seat and armrest in order to leave maximum clearance on the stairway or to send down the lift into its lower stop position.
- 7) Remove the keys from the armrest to prevent unintended use.

Charging the battery

The two 12V batteries that power the chairlift are charged at each landing station using the AC charger. The seat must therefore always park in one of the landing stations.

The seat is equipped with the following audio signals:

- If the seat stops outside the station and thus is not charging, after 5 seconds every second a short beeping sound will appear. Take the platform to some of the landing stations so it can charge. The acoustic signal should then stop. If not check if the charger is plugged in and there is 24V between the charging plate and the rack on the rail. If the problem persists please contact the installing company.
- If the battery capacity is low or insufficient for further trouble-free operation every 2.5 seconds a long beep will appear during driving of the chairlift. In this case park the lift in the landing station for some time in order the batteries can recharge.

Fault detection and trouble shooting

The lift is equipped with a number of electrical and mechanical safety features. If the lift is not working check the following points:

- Is the green main power LED next to the main power switch on the carriage on?
- Is the armrest folded down for driving while sitting on the seat?
- Is the hall call LED on when trying to call or send the lift? Check batteries.
- Is the swivel lever properly engaged at the 0° driving position?
- Are any of the contact safety covers pressed. Check side covers, footrest cover as well as covers on the upper and lower trolley (plastic covers around the rail)
- Is driving in both directions blocked or only in one direction?
- Is the main power supply to the charger ok? Check fuses.
- When calling the installation company please have the serial number of the lift ready.

Emergency drive wheel

In case the chairlift stops working on the driveway the unit can be moved by turning the emergency handwheel. The handwheel has to be entered on the front of the drive unit into a hole next to the main power switch. Before using the handwheel turn off the main power switch.

The handwheel has to be pushed into the hole with a certain force and can then be turned in the desired direction. The movement of the unit will be slow and the lift should be moved to the nearest acceptable position.

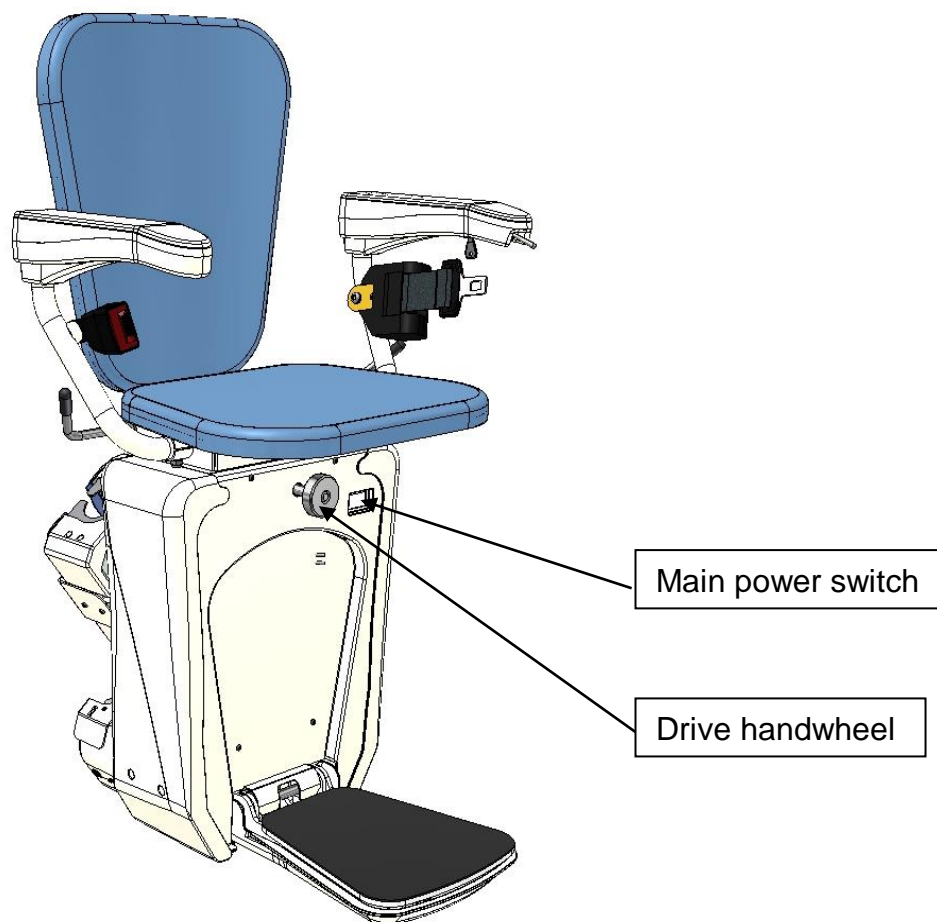

Maintenance

Regular maintenance of the entire stairlift is particularly important. The minimum inspection intervals (also with minimal frequency of usage) are:

- 1st service inspection after about 6 months after commissioning.
- Additional inspections depending on usage, but at least every 12 months.

Check regularly, at least once a week following points on your seat:

- The seat should not start if the armrest with the operation is in the raised position.
- The lift should not start if the seat is not in the 0° rotation position.
- Check functions of all contact safety covers on trolleys, footrest and on the side of the carriage. These covers must stop the lift when being pushed in the driving direction.
- Check all visible parts for damage or deformation.
- If you release the joystick or the push button the lift must immediately stop.
- Regularly clean the rails from dust and other dirt.
- Keep the area around the rails and the chair travel way free of any obstacles.

Cleaning:

Before cleaning you must always turn off the main power switch. To clean the whole device use a damp cloth and ordinary non-abrasive household cleaners. For cleaning the upholstery material of the seat and the backrest also use a damp cloth to remove dirt.

Maintenance Record

Date	Time	Reason for call	Comments	Dealer